

**PROTECTED DIGITAL AUDIO AMPLIFIER**

**Features**

- Integrated analog input Class D audio amplifier driver in a small 16 pin package
- Floating inputs enable easy half bridge implementation
- Programmable bidirectional over-current protection with self-reset function
- Programmable preset deadtime for improved THD performances
- Start and stop click noise reduction
- High noise immunity
- ±100 V ratings deliver up to 500 W in output power
- Operates up to 800 kHz
- RoHS compliant

**Product Summary**

V <sub>OFFSET</sub> (max)		± 100 V
Gate driver	Io+	1.0 A
	Io-	1.2 A
Selectable Deadtime		25/40/65/105 ns
OC protection delay (max)		500 ns
DC offset		<20 mV
PWM frequency		~800 kHz
Error amplifier open loop gain		>60 dB
THD+N* (1kHz, 50W, 4Ω)		0.01 %
Residual Noise* (AES-17 Filter)		200 μVrms

\* Measured with recommended circuit

**Typical Applications**

- Home theater systems
- Mini component stereo systems
- Powered speaker systems
- General purpose audio power amplifiers

**Package Options**



SOIC16N



PDIP16

**Typical Connection Diagram**

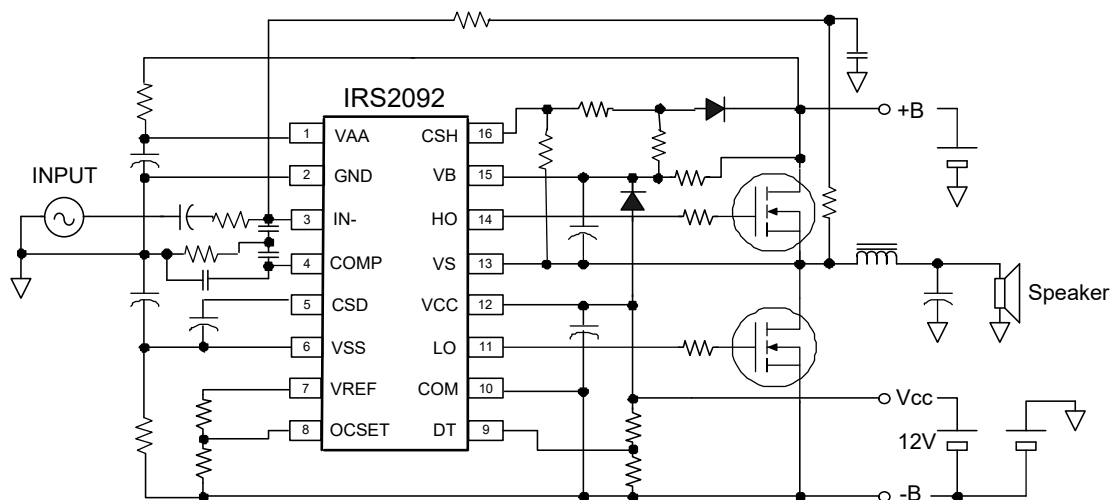

<b>Table of Contents</b>	<b>Page</b>
Description	3
Simplified Block Diagram	4
Typical Application Diagram	4
Qualification Information	5
Absolute Maximum Ratings	6
Recommended Operating Conditions	7
Electrical Characteristics	8
Waveform Definitions	11
Functional Block Diagram	12
Input/Output Pin Equivalent Circuit Diagram	13
Lead Definitions	14
Lead Assignments	14
Package Details	15
Tape and Reel Details	16
Part Marking Information	17
Ordering Information	17

## Description

The IRS2092 is a high voltage, high performance Class D audio amplifier driver with PWM modulator and protection. In conjunction with two external MOSFET and a few external components, a complete Class D audio amplifier with protection can be realized.

International Rectifier's proprietary noise isolation technology allows high current gate drive stage and high speed low noise error amplifier reside on a single small silicon die.

Open elements of PWM modulator section allow flexible PWM topology implementation

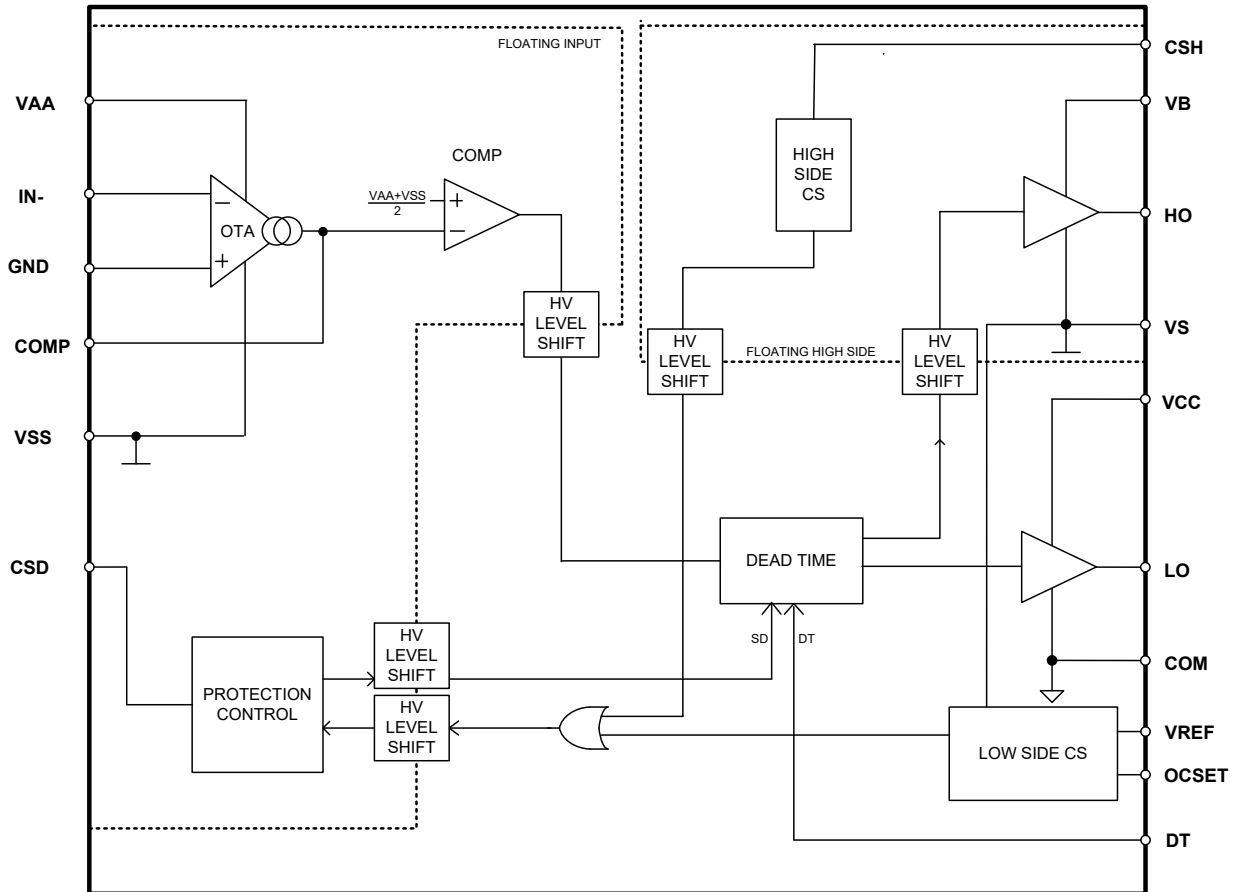
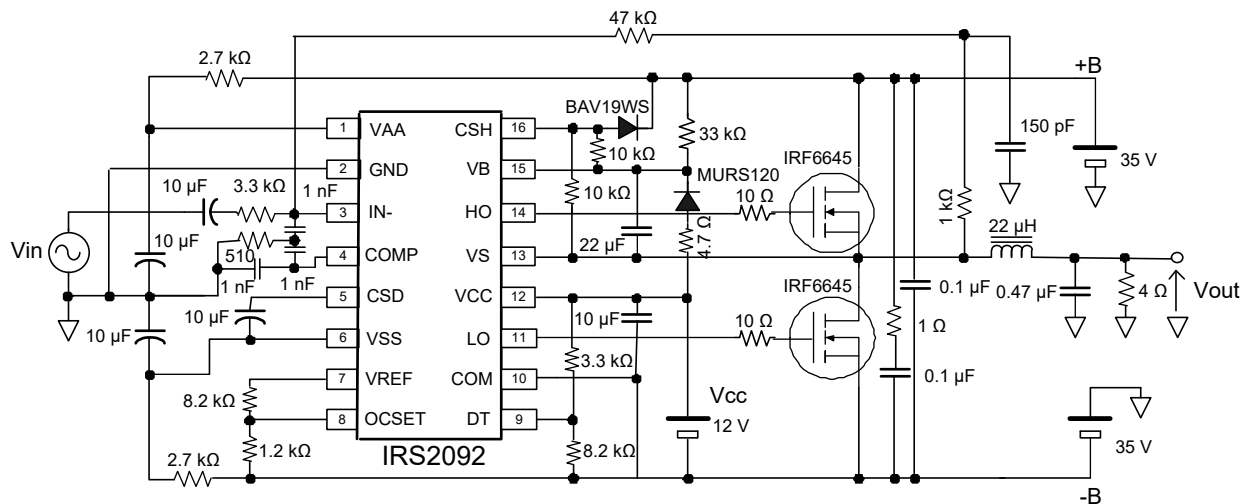
**Simplified Block Diagram**

**Typical Application Diagram**

**Qualification Information**

<b>Qualification Level</b>		Industrial <sup>††</sup> (per JEDEC JESD 47E)	
		Comments: This IC has passed JEDEC's Industrial qualification. IR's Consumer qualification level is granted by extension of the higher Industrial level.	
<b>Moisture Sensitivity Level</b>		SOIC16N	MSL2 <sup>†††</sup> (per IPC/JEDEC J-STD-020C)
		DIP16	Not applicable
<b>ESD</b>	<b>Machine Model</b>	Class B (per JEDEC standard JESD22-A114D)	
	<b>Human Body Model</b>	Class 2 (per EIA/JEDEC standard EIA/JESD22-A115-A)	
	<b>Charged Device Model</b>	Class IV (per JEDEC standard JESD22-C101C)	
<b>IC Latch-Up Test</b>		Class I, Level A (per JESD78A)	
<b>RoHS Compliant</b>		Yes	

† Qualification standards can be found at International Rectifier's web site <http://www.irf.com/>

†† Higher qualification ratings may be available should the user have such requirements. Please contact your International Rectifier sales representative for further information.

††† Higher MSL ratings may be available for the specific package types listed here. Please contact your International Rectifier sales representative for further information.

## Absolute Maximum Ratings

Absolute Maximum Ratings indicate sustained limits beyond which damage to the device may occur. All voltage parameters are absolute voltages referenced to COM; all currents are defined positive into any lead. The Thermal Resistance and Power Dissipation ratings are measured under board mounted and still air conditions

Symbol	Definition	Min	Max	Units	
$V_B$	High side floating supply voltage	-0.3	220	V	
$V_S$	High side floating supply voltage <sup>††</sup>	$V_B - 20$	$V_B + 0.3$		
$V_{HO}$	High side floating output voltage	$V_S - 0.3$	$V_B + 0.3$		
$V_{CSH}$	CSH pin input voltage	$V_S - 0.3$	$V_B + 0.3$		
$V_{CC}$	Low side fixed supply voltage <sup>††</sup>	-0.3	20		
$V_{LO}$	Low side output voltage	-0.3	$V_{CC} + 0.3$		
$V_{AA}$	Floating input positive supply voltage <sup>††</sup>	(See $I_{AAZ}$ )	210		
$V_{SS}$	Floating input negative supply voltage <sup>††</sup>	-1 (See $I_{SSZ}$ )	GND + 0.3		
$V_{GND}$	Floating input supply ground voltage	$V_{SS} - 0.3$ (See $I_{SSZ}$ )	$V_{AA} + 0.3$ (See $I_{AAZ}$ )		
$I_{IN-}$	Inverting input current <sup>†</sup>	---	±3	mA	
$V_{CSD}$	SD pin input voltage	$V_{SS} - 0.3$	$V_{AA} + 0.3$	V	
$V_{COMP}$	COMP pin input voltage	$V_{SS} - 0.3$	$V_{AA} + 0.3$		
$V_{DT}$	DT pin input voltage	-0.3	$V_{CC} + 0.3$		
$V_{OCSET}$	OCSET pin input voltage	-0.3	$V_{CC} + 0.3$		
$I_{AAZ}$	Floating input positive supply zener clamp current <sup>††</sup>	---	20	mA	
$I_{SSZ}$	Floating input negative supply zener clamp current <sup>††</sup>	---	20		
$I_{CCZ}$	Low side supply zener clamp current <sup>†††</sup>	---	10		
$I_{BSZ}$	Floating supply zener clamp current <sup>†††</sup>	---	10		
$I_{OREF}$	Reference output current	---	5		
$dV_S/dt$	Allowable $V_S$ voltage slew rate	---	50	V/ns	
$dV_{SS}/dt$	Allowable $V_{SS}$ voltage slew rate <sup>†††</sup>	---	50	V/ms	
$P_d$	Maximum power dissipation @ $T_A \leq +25^\circ\text{C}$	SOIC16N	---	1.0	W
		DIP16	---	1.6	
$R_{thJA}$	Thermal resistance, Junction to ambient	SOIC16N	---	115	°C/W
		DIP16	---	75	
$T_J$	Junction Temperature	---	150	°C	
$T_S$	Storage Temperature	-55	150	°C	
$T_L$	Lead temperature (soldering, 10 seconds)	---	300	°C	

† IN- contains clamping diode to GND.

††  $V_{DD} - IN+$ , GND -  $V_{SS}$ ,  $V_{CC} - COM$  and  $V_B - V_S$  contain internal shunt zener diodes. Please note that the voltage ratings of these can be limited by the clamping current.

††† For the rising and falling edges of step signal of 10 V.  $V_{SS} = 15\text{ V}$  to 200 V.

### Recommended Operating Conditions

For proper operation, the device should be used within the recommended conditions below. The  $V_S$  and COM offset ratings are tested with supplies biased at  $V_{AA}-V_{SS}=10$  V,  $V_{CC}=12$  V and  $V_B-V_S=12$  V. All voltage parameters are absolute voltages referenced to COM; all currents are defined positive into any lead.

Symbol	Definition	Min.	Max.	Units	
$V_B$	High side floating supply absolute voltage	$V_S + 10$	$V_S + 18$	V	
$V_S$	High side floating supply offset voltage	†	200		
$I_{AAZ}$	Floating input positive supply zener clamp current	1	11	mA	
$I_{SSZ}$	Floating input negative supply zener clamp current	1	11		
$V_{SS}$	Floating input supply absolute voltage	0	200	V	
$V_{HO}$	High side floating output voltage	$V_S$	$V_B$		
$V_{CC}$	Low side fixed supply voltage	10	18		
$V_{LO}$	Low side output voltage	0	$V_{CC}$		
$V_{GND}$	GND pin input voltage	$V_{SS}^{†††}$	$V_{AA}^{†††}$		
$V_{IN-}$	Inverting input voltage	$V_{GND} - 0.5$	$V_{GND} + 0.5$		
$V_{CSD}$	CSD pin input voltage	$V_{SS}$	$V_{AA}$		
$V_{COMP}$	COMP pin input voltage	$V_{SS}$	$V_{AA}$		
$C_{COMP}$	COMP pin phase compensation capacitor to GND	1	-		nF
$V_{DT}$	DT pin input voltage	0	$V_{CC}$		V
$I_{OREF}$	Reference output current to COM <sup>††</sup>	0.3	0.8	mA	
$V_{OCSET}$	OCSET pin input voltage	0.5	5	V	
$V_{CSH}$	CSH pin input voltage	$V_S$	$V_B$		
$dV_{SS}/dt$	Allowable $V_{SS}$ voltage slew rate upon power-up <sup>††††</sup>	-	50	V/ms	
$I_{PW}$	Input pulse width	10 <sup>†††††</sup>	-	ns	
$f_{SW}$	Switching Frequency	-	800	kHz	
$T_A$	Ambient Temperature	-40	125	°C	

† Logic operational for  $V_S$  equal to  $-5$  V to  $+200$  V. Logic state held for  $V_S$  equal to  $-5$  V to  $-V_{BS}$ .

†† Nominal voltage for  $V_{REF}$  is 5.1 V.  $I_{OREF}$  of 0.3 – 0.8 mA dictates total external resistor value on  $V_{REF}$  to be 6.3 k $\Omega$  to 16.7 k $\Omega$ .

††† GND input voltage is limited by  $I_{AAZ}$  and  $I_{SSZ}$ .

††††  $V_{SS}$  ramps up from 0 V to 200 V.

††††† Output logic status may not respond correctly if input pulse width is smaller than the minimum pulse width.

**Electrical Characteristics**
 $V_{CC}, V_{BS} = 12\text{ V}$ ,  $V_{SS} = V_S = \text{COM} = 0\text{ V}$ ,  $V_{AA} = 10\text{ V}$ ,  $C_L = 1\text{ nF}$  and  $T_A = 25\text{ }^\circ\text{C}$  unless otherwise specified.

Symbol	Definition	Min	Typ	Max	Units	Test Conditions
<b>Low Side Supply</b>						
$UV_{CC+}$	Vcc supply UVLO positive threshold	8.4	8.9	9.4	V	
$UV_{CC-}$	Vcc supply UVLO negative threshold	8.2	8.7	9.2		
$UV_{CCHYS}$	$UV_{CC}$ hysteresis	-	0.2	-		
$I_{QCC}$	Low side quiescent current	-	-	3	mA	$V_{DT} = V_{CC}$
$V_{CLAMPL}$	Low side zener diode clamp voltage	19.6	20.4	21.6	V	$I_{CC} = 5\text{ mA}$
<b>High Side Floating Supply</b>						
$UV_{BS+}$	High side well UVLO positive threshold	8.0	8.5	9.0	V	
$UV_{BS-}$	High side well UVLO negative threshold	7.8	8.3	8.8		
$UV_{BSHYS}$	$UV_{BS}$ hysteresis	-	0.2	-		
$I_{QBS}$	High side quiescent current	-	-	1	mA	
$I_{LKH}$	High to Low side leakage current	-	-	50	$\mu\text{A}$	$V_B = V_S = 200\text{ V}$
$V_{CLAMPH}$	High side zener diode clamp voltage	19.6	20.4	21.6	V	$I_{BS} = 5\text{ mA}$
<b>Floating Input Supply</b>						
$UV_{AA+}$	$VA+$ , $VA-$ floating supply UVLO positive threshold from $V_{SS}$	8.2	8.7	9.2	V	$V_{SS} = 0\text{ V}$ , GND pin floating
$UV_{AA-}$	$VA+$ , $VA-$ floating supply UVLO negative threshold from $V_{SS}$	7.7	8.2	8.7		$V_{SS} = 0\text{ V}$ , GND pin floating
$UV_{AAHYS}$	$UV_{AA}$ hysteresis	-	0.5	-		$V_{SS} = 0\text{ V}$ , GND pin floating
$I_{QAA0}$	Floating Input positive quiescent supply current	-	0.5	2	mA	$V_{AA} = 10\text{ V}$ , $V_{SS} = 0\text{ V}$ , $V_{CSD} = V_{SS}$
$I_{QAA1}$	Floating Input positive quiescent supply current	-	8	11		$V_{AA} = 10\text{ V}$ , $V_{SS} = 0\text{ V}$ , $V_{CSD} = V_{AA}$
$I_{QAA2}$	Floating Input positive quiescent supply current	-	8	11		$V_{AA} = 10\text{ V}$ , $V_{SS} = 0\text{ V}$ , $V_{CSD} = \text{GND}$
$I_{LKM}$	Floating input side to Low side leakage current	-	-	50	$\mu\text{A}$	$V_{AA} = V_{SS} = V_{GND} = 100\text{ V}$
$V_{CLAMP+}$	$V_{AA}$ floating supply zener diode clamp voltage, positive, with respect to GND	6.0	7.0	8.0	V	$I_{AA} = 5\text{ mA}$ , $I_{SS} = 5\text{ mA}$ , $V_{GND} = 0\text{ V}$ , $V_{CSD} = V_{SS}$
$V_{CLAMP-}$	$V_{SS}$ floating supply zener diode clamp voltage, negative, with respect to GND	-8.0	-7.0	-6.0		$I_{AA} = 5\text{ mA}$ , $I_{SS} = 5\text{ mA}$ , $V_{GND} = 0\text{ V}$ , $V_{CSD} = V_{SS}$



**Electrical Characteristics (cont'd)**
 $V_{CC}, V_{BS} = 12\text{ V}$ ,  $V_{SS} = V_S = \text{COM} = 0\text{ V}$ ,  $V_{AA} = 10\text{ V}$ ,  $C_L = 1\text{ nF}$  and  $T_A = 25\text{ }^\circ\text{C}$  unless otherwise specified.

<b>Audio Input</b> ( $V_{GND}=0$ , $V_{AA}=5\text{V}$ , $V_{SS}=-5\text{V}$ )						
$V_{OS}$	Input offset voltage	-15	0	15	mV	
$I_{BIN}$	Input bias current	-	-	40	nA	
BW	Small signal bandwidth	-	9	-	MHz	$C_{COMP}=2\text{ nF}$ , $R_f=3.3\text{ k}\Omega$
$V_{COMP}$	OTA Output voltage	$V_{AA}-1$	-	$V_{SS}+1$	V	
$g_m$	OTA transconductance	-	100	-	mS	$V_{IN}=10\text{ mV}$
$G_V$	OTA gain	60	-	-	dB	
$V_{Nrms}$	OTA input noise voltage	-	250	-	mVrms	BW=20 kHz, Resolution BW=22 Hz Fig.5
SR	Slew rate	-	$\pm 5$	-	V/us	$C_{COMP}=1\text{ nF}$
CMRR	Common-mode rejection ratio	-	60	-	dB	
PSRR	Supply voltage rejection ratio	-	65	-		
<b>PWM comparator</b>						
$V_{thPWM}$	PWM comparator threshold in COMP	-	$(V_{AA}-V_{SS})/2$	-	V	
$f_{OTA}$	COMP pin star-up local oscillation frequency	0.7	1.0	1.5	MHz	$V_{CSD} = \text{GND}$
<b>Protection</b>						
$V_{REF}$	Reference output voltage	4.8	5.1	5.4	V	$I_{OREF} = 0.5\text{ mA}$
$V_{thOCL}$	Low side OC threshold in $V_S$	1.1	1.2	1.3		OCSET=1.2 V, Fig.6
$V_{thOCH}$	High side OC threshold in $V_{CSH}$	$1.1+ V_S$	$1.2+ V_S$	$1.3+ V_S$		$V_S=200\text{ V}$ ,
$V_{th1}$	CSD pin shutdown release threshold	$0.62 \times V_{AA}$	$0.70 \times V_{AA}$	$0.78 \times V_{AA}$	$\mu\text{A}$	
$V_{th2}$	CSD pin self reset threshold	$0.26 \times V_{AA}$	$0.30 \times V_{AA}$	$0.34 \times V_{AA}$		
$I_{CSD+}$	CSD pin discharge current	70	100	130		$V_{CSD} = V_{SS} + 5\text{ V}$
$I_{CSD-}$	CSD pin charge current	70	100	130		$V_{CSD} = V_{SS} + 5\text{ V}$
$t_{SD}$	Shutdown propagation delay from $V_{CSD} > V_{SS} + V_{thOCH}$ to Shutdown	-	-	250	ns	
$t_{OCH}$	Propagation delay time from $V_{CSH} > V_{thOCH}$ to Shutdown	-	-	500		Fig.3
$t_{OCL}$	Propagation delay time from $V_S > V_{thOCL}$ to Shutdown	-	-	500		Fig.4

**Electrical Characteristics (cont'd)**
 $V_{CC}, V_{BS} = 12\text{ V}$ ,  $V_{SS} = V_S = \text{COM} = 0\text{ V}$ ,  $V_{AA} = 10\text{ V}$ ,  $C_L = 1\text{ nF}$  and  $T_A = 25\text{ }^\circ\text{C}$  unless otherwise specified.

Gate Driver						
$I_{o+}$	Output high short circuit current (Source)	-	1.0	-	A	$V_o = 0\text{ V}$ , $PW \leq 10\text{ }\mu\text{s}$
$I_{o-}$	Output low short circuit current (Sink)	-	1.2	-	A	$V_o = 12\text{ V}$ , $PW \leq 10\text{ }\mu\text{s}$
$V_{OL}$	Low level out put voltage LO – COM, HO - VS	-	-	0.1	V	$I_o = 0\text{ A}$
$V_{OH}$	High level out put voltage VCC – LO, VB - HO	-	-	1.4		
$t_{on}$	High and low side turn-on propagation delay	-	360	-	ns	$V_{DT} = V_{CC}$
$t_{off}$	High and low side turn-off propagation delay	-	335	-		$V_{DT} = V_{CC}$
$t_r$	Turn-on rise time	-	20	50		
$t_f$	Turn-off fall time	-	15	35		
DT1	Deadtime: LO turn-off to HO turn-on ( $DT_{LO-HO}$ ) & HO turn-off to LO turn-on ( $DT_{HO-LO}$ )	15	25	35		$V_{DT} > V_{DT1}$ ,
DT2	Deadtime: LO turn-off to HO turn-on ( $DT_{LO-HO}$ ) & HO turn-off to LO turn-on ( $DT_{HO-LO}$ )	25	40	55		$V_{DT1} > V_{DT} > V_{DT2}$ ,
DT3	Deadtime: LO turn-off to HO turn-on ( $DT_{LO-HO}$ ) & HO turn-off to LO turn-on ( $DT_{HO-LO}$ )	50	65	85		$V_{DT2} > V_{DT} > V_{DT3}$ ,
DT4	Deadtime: LO turn-off to HO turn-on ( $DT_{LO-HO}$ ) & HO turn-off to LO turn-on ( $DT_{HO-LO}$ ) $V_{DT} = V_{DT4}$	85	105	135		$V_{DT3} > V_{DT} > V_{DT4}$ ,
$V_{DT1}$	DT mode select threshold 2	$0.51 \times V_{CC}$	$0.57 \times V_{CC}$	$0.63 \times V_{CC}$	V	
$V_{DT2}$	DT mode select threshold 3	$0.32 \times V_{CC}$	$0.36 \times V_{CC}$	$0.40 \times V_{CC}$		
$V_{DT3}$	DT mode select threshold 4	$0.21 \times V_{CC}$	$0.23 \times V_{CC}$	$0.25 \times V_{CC}$		

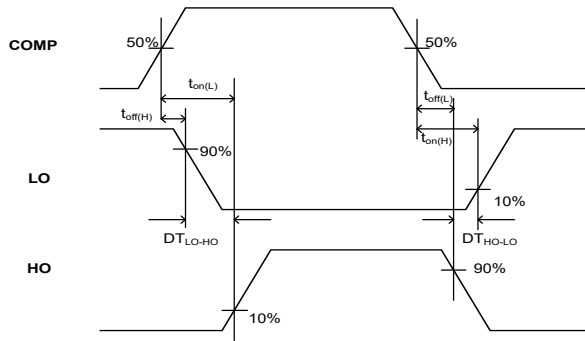
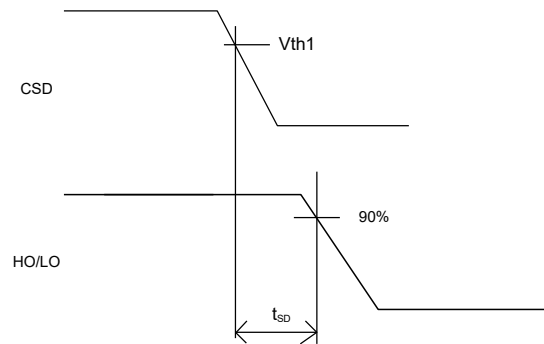
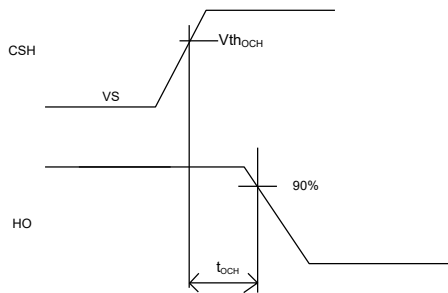
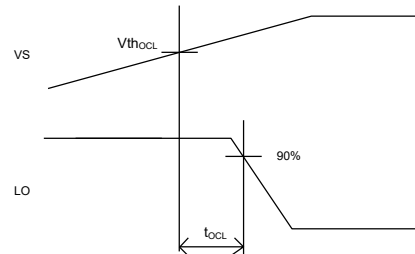
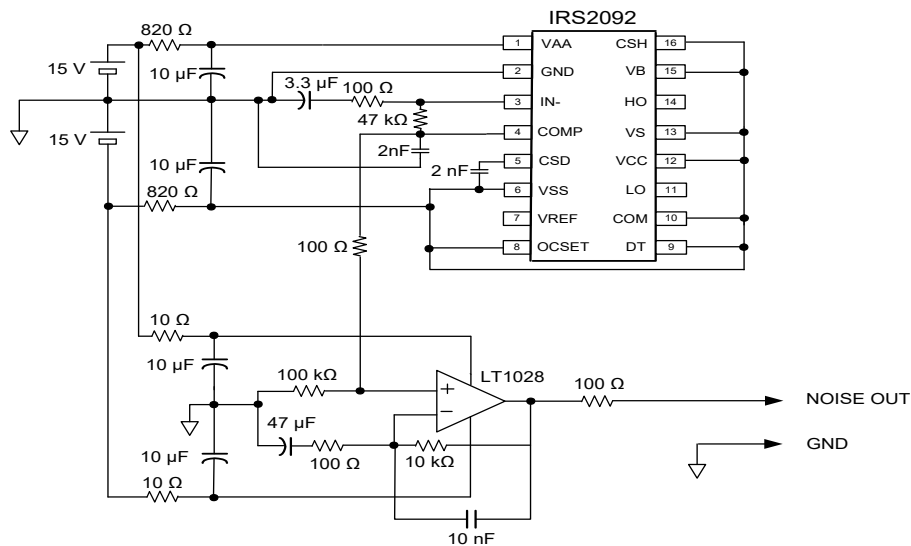
**Waveform Definitions**

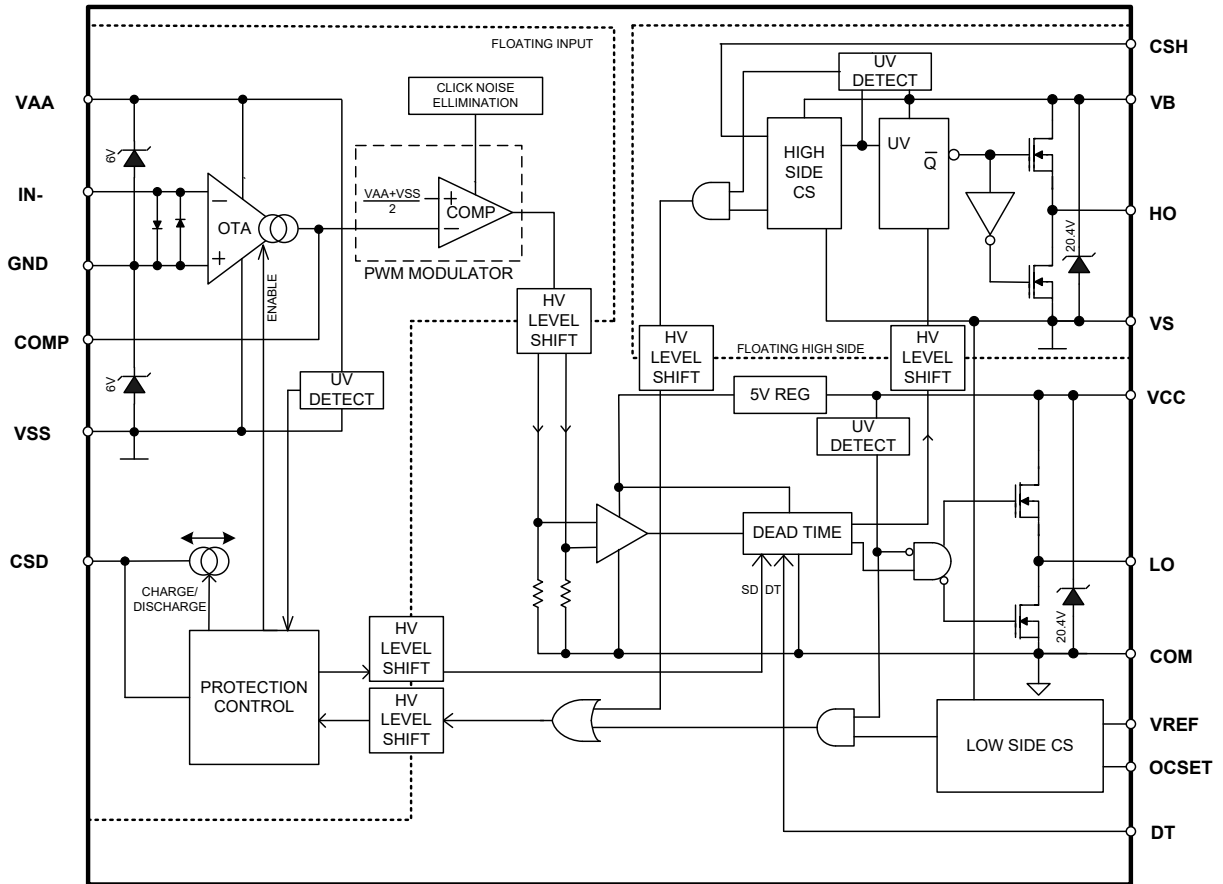
**Figure 1: Switching Time Waveform Definitions**

**Figure 2: CSD to Shutdown Waveform Definitions**

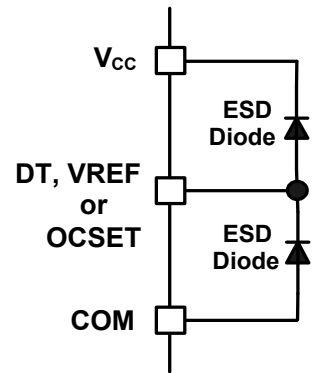
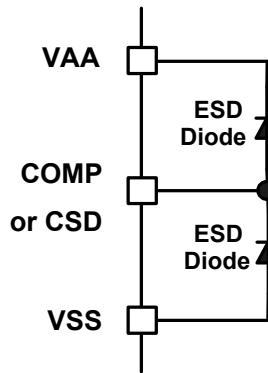
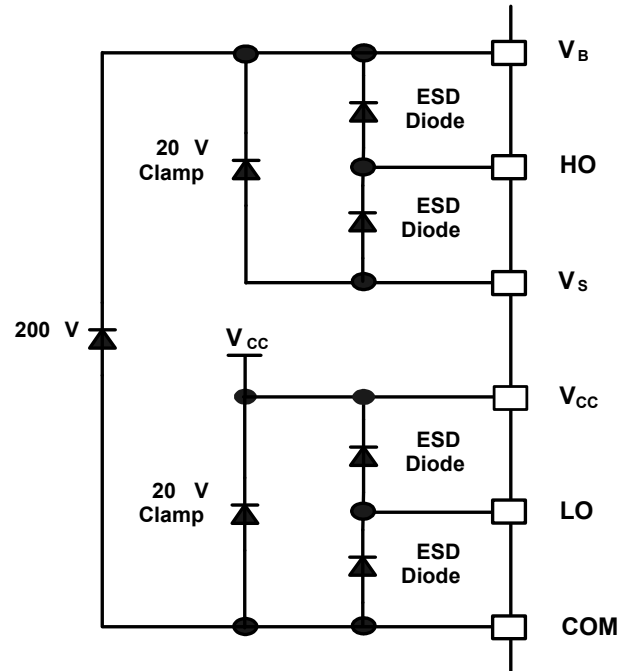
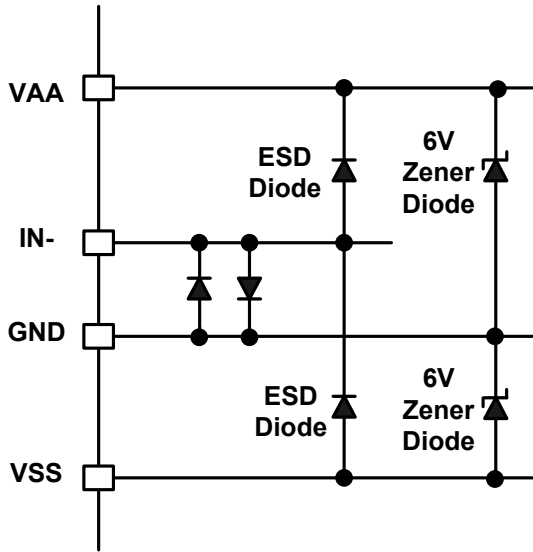
**Figure 3:  $V_S > V_{th_{OCL}}$  to Shutdown Waveform**

**Figure 4:  $V_{CSH} > V_{th_{OCH}}$  to Shutdown Waveform**

**Figure 5: OTA input noise voltage mesurent circuit**

**Functional Block Diagram: IRS2092**

## Input/Output Pin Equivalent Circuit Diagrams: IRS2092



### Lead Definitions: IRS2092

Pin #	Symbol	Description
1	VAA	Floating input positive supply
2	GND	Floating input supply return
3	IN-	Analog inverting input
4	COMP	Phase compensation input, comparator input
5	CSD	Shutdown timing capacitor
6	VSS	Floating input negative supply
7	VREF	5V reference voltage to program OCSET pin
8	OCSET	Low side over current threshold setting
9	DT	Deadtime program input
10	COM	Low side supply return
11	LO	Low side output
12	VCC	Low side supply
13	VS	High side floating supply return
14	HO	High side output
15	VB	High side floating supply
16	CSH	High side over current sensing input

### Lead Assignments

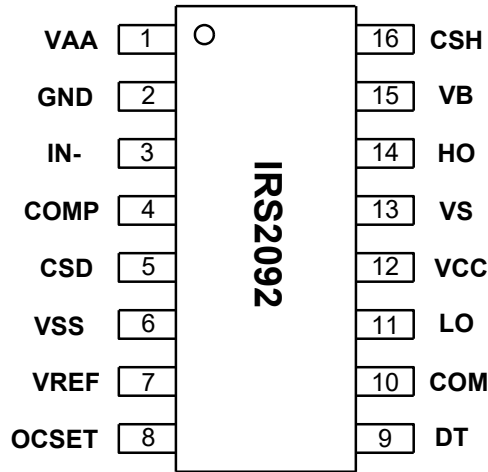

**PDIP16 and SOIC16N**

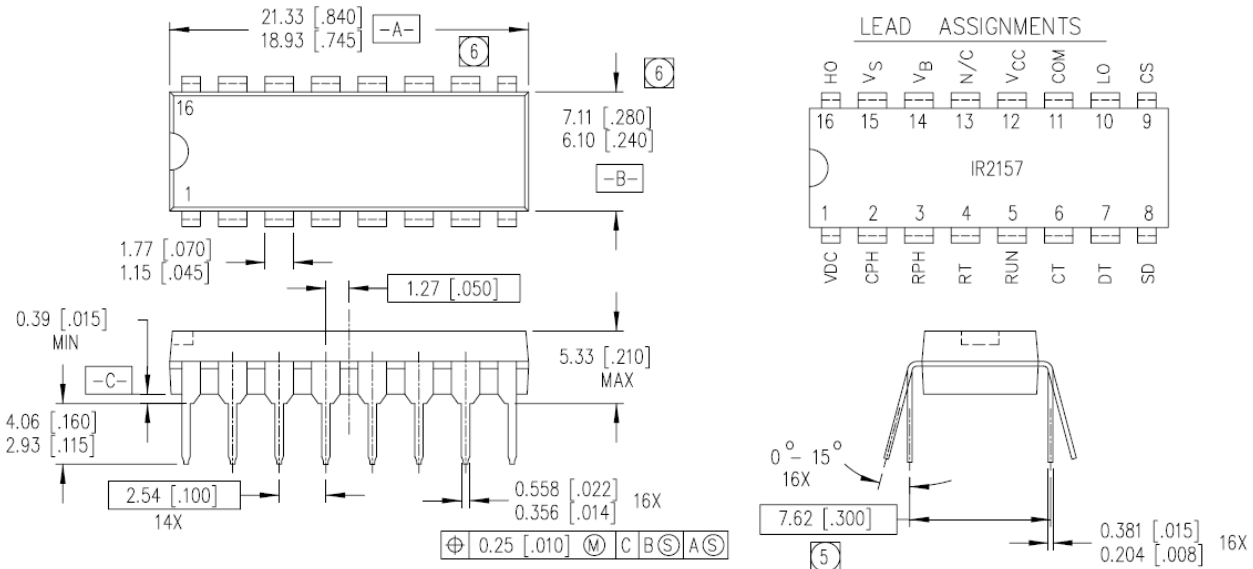
**Package Details: PDIP16**

**NOTES:**

1. DIMENSIONING & TOLERANCING PER ANSI Y14.5M-1982.
2. CONTROLLING DIMENSION: INCH.
3. DIMENSIONS ARE SHOWN IN MILLIMETERS [INCHES].
4. OUTLINE CONFORMS TO JEDEC OUTLINE MS-001AA.

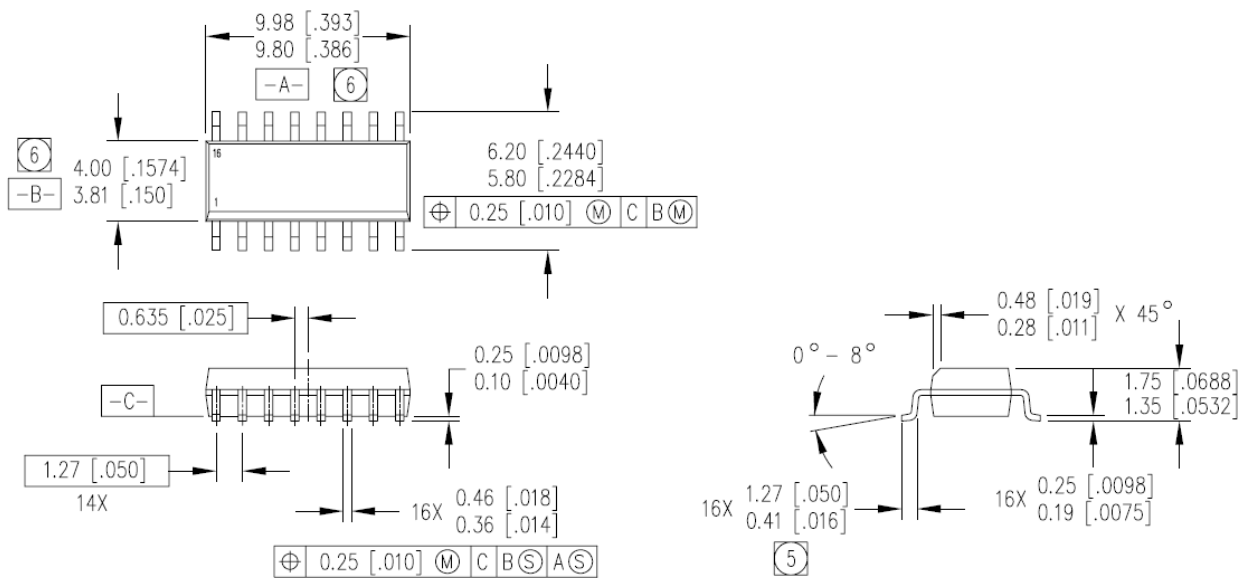
- ⑤ MEASURED WITH THE LEADS CONSTRAINED TO BE PERPENDICULAR TO DATUM PLANE C.
- ⑥ DIMENSION DOES NOT INCLUDE MOLD PROTUSIONS. MOLD PROTUSIONS SHALL NOT EXCEED 0.25 [.010].

**Package Details: SOIC16N**

**NOTES:**

1. DIMENSIONING & TOLERANCING PER ANSI Y14.5M-1982.
2. CONTROLLING DIMENSION: MILLIMETER
3. DIMENSIONS ARE SHOWN IN MILLIMETERS [INCHES].
4. OUTLINE CONFORMS TO JEDEC OUTLINE MS-012AC.

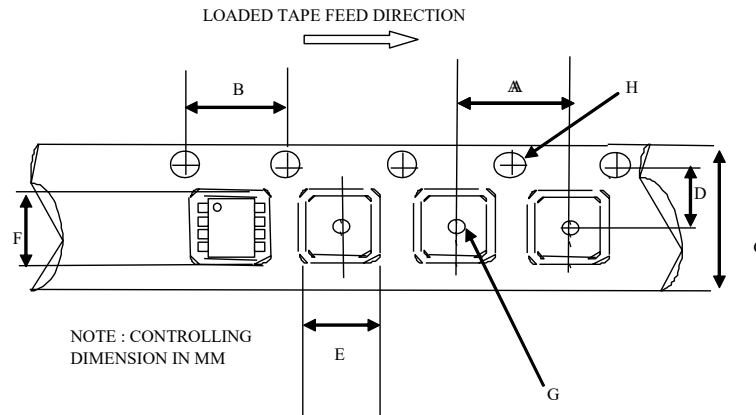
- ⑤ DIMENSION IS THE LENGTH OF LEAD FOR SOLDERING TO A SUBSTRATE.
- ⑥ DIMENSION DOES NOT INCLUDE MOLD PROTUSIONS. MOLD PROTUSIONS SHALL NOT EXCEED 0.15 [.006].

**Tape and Reel Details: SOIC16N**

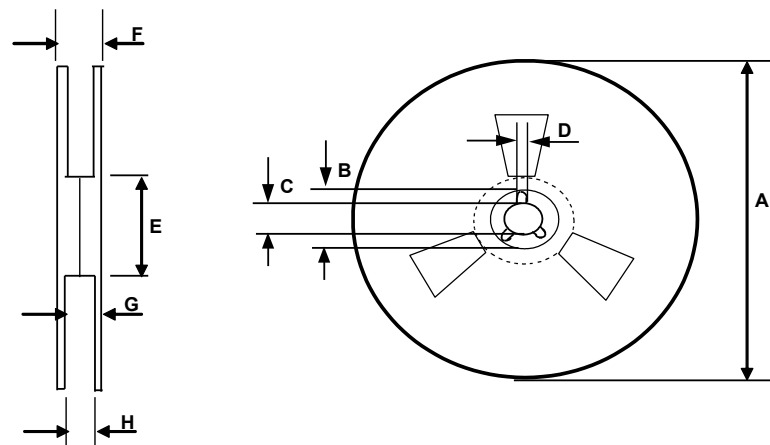
**CARRIER TAPE DIMENSION FOR 16SOICN**

Code	Metric		Imperial	
	Min	Max	Min	Max
A	7.90	8.10	0.311	0.318
B	3.90	4.10	0.153	0.161
C	15.70	16.30	0.618	0.641
D	7.40	7.60	0.291	0.299
E	6.40	6.60	0.252	0.260
F	10.20	10.40	0.402	0.409
G	1.50	n/a	0.059	n/a
H	1.50	1.60	0.059	0.062

**REEL DIMENSIONS FOR 16SOICN**

Code	Metric		Imperial	
	Min	Max	Min	Max
A	329.60	330.25	12.976	13.001
B	20.95	21.45	0.824	0.844
C	12.80	13.20	0.503	0.519
D	1.95	2.45	0.767	0.096
E	98.00	102.00	3.858	4.015
F	n/a	22.40	n/a	0.881
G	18.50	21.10	0.728	0.830
H	16.40	18.40	0.645	0.724



## Part Marking Information

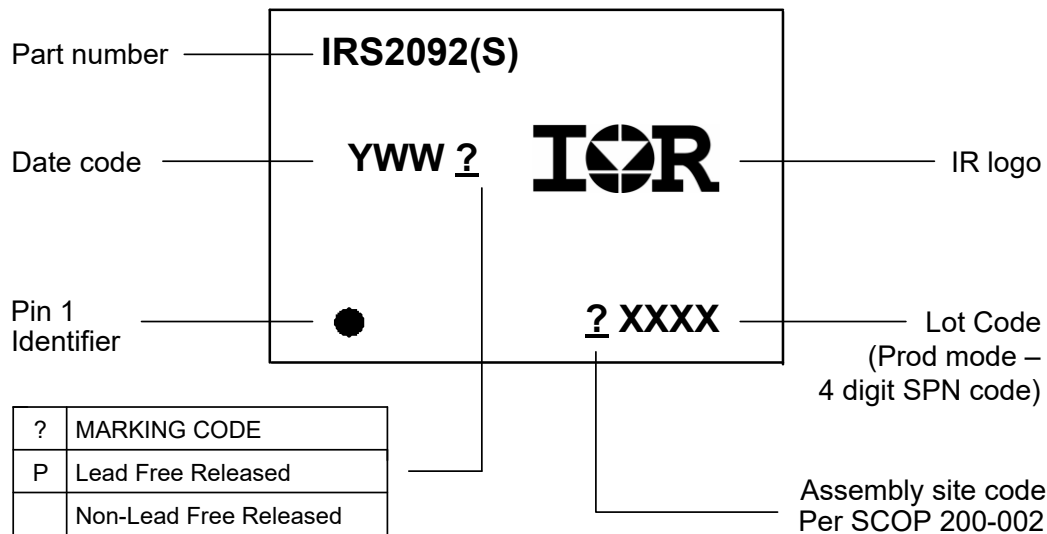

## Ordering Information

Base Part Number	Package Type	Standard Pack		Complete Part Number
		Form	Quantity	
IRS2092	PDIP16	Tube/Bulk	25	IRS2092PBF
	SOIC16N	Tube/Bulk	45	IRS2092SPBF
		Tape and Reel	2500	IRS2092STRPBF

The information provided in this document is believed to be accurate and reliable. However, International Rectifier assumes no responsibility for the consequences of the use of this information. International Rectifier assumes no responsibility for any infringement of patents or of other rights of third parties which may result from the use of this information. No license is granted by implication or otherwise under any patent or patent rights of International Rectifier. The specifications mentioned in this document are subject to change without notice. This document supersedes and replaces all information previously supplied.

For technical support, please contact IR's Technical Assistance Center  
<http://www.irf.com/technical-info/>

**WORLD HEADQUARTERS:**  
 233 Kansas St., El Segundo, California 90245  
 Tel: (310) 252-7105

# Mouser Electronics

Authorized Distributor

Click to View Pricing, Inventory, Delivery & Lifecycle Information:

[Infineon:](#)

[IRS2092PBF](#) [IRS2092STRPBF](#) [IRS2092SPBF](#)